

Conex Compression

Compression system technical specifications and product range



List of Contents	Page
General Information	3
One Fitting for Many Tubes	4
Design	5
Performance	6
Making a Joint	7
High Torque Installations	8
Flanged Fittings	9
Installation Dimensions (capnuts hand tight)	10-12
Product Range	13
Compression Fittings - Brass and DZR 6mm to 108mm	13-17
Accessories for Compression Joints	18-19
Manifolds	20
Matt Chrome Plated Compression Fittings	20-21
ISOCONE X For use with MDPE, PB and PE-X Pipe	22
ISOCONE X Accessories	23
Accessories for use with Imperial Polythene Pipe	23
Copper Tubular Traps	24-25
Bottle Traps	25
Traps - Waste Fittings	26
Accessories	27
Manifolds	27
Stop Valves / Check Valves	28
Draining Taps	28
Fullway Gate Valves to BS5154/B	28
Serviceman Valves to BS6675	28
Plug Taps / Automatic Air Vent / Washing Machine Valve	29
Brass Float Valves	29
Lever Ball Valves	29

General Information

Conex type 'A' non-manipulative standard compression fittings are manufactured in accordance with EN 1254-2 and 4 (formerly BS 864: Part 2), in sizes from 6mm to 108mm.

Applications and Uses

The versatility of the fitting enables it to be used for connecting tubes in a wide variety of domestic and commercial applications such as plumbing, heating, fluid distribution, air pressure lines and air conditioning. Conex compression fittings are especially advantageous in retrofit plumbing schemes, where space is confined and/or the use of heat must be avoided. The ability to connect different types of tube is of special importance encouraging users such as original equipment manufacturers to incorporate Conex compression fittings within their designs. The fitting's simplicity, versatility and speed of installation makes it a popular choice with installers.

Size Availability

6mm–108mm, suitable for connecting copper tubes in accordance with EN 1057 and many other standards including ISO 274.

Fittings are also suitable for connecting low carbon steel, stainless steel and many types of plastic pipe including crossed linked polyethylene (PE-X) and polybutylene (PB) with size compatible outside diameters.

N.B. When using compression fittings with soft copper tube to EN 1057 - R220 or plastic pipe it is essential that an appropriate tube liner is also fitted.

Imperial copper tube to BS 659 in sizes $\frac{3}{8}$ ", $\frac{1}{2}$ ", 2" and $2\frac{1}{2}$ " sizes can be readily joined using 12mm, 15mm, 54mm and 66.7mm fittings respectively. Other sizes can be joined using special adaptors in the range.

Reference to our current price list and catalogue will provide more information about the range.

Fitting Materials

Fittings are generally produced in duplex brass but, to counteract the problem of dezincification and meet certain water regulation requirements, they are also available, or may only be available, in dezincification resistant (DZR) brass or as dezincification immune gunmetal.

Dezincification of ordinary duplex brass fittings may occur under certain water supply conditions. The Conex DZR range of fittings can safely be used in these circumstances.

The DZR alloy, a joint development of manufacturers and the British Non-Ferrous Metal Technology Centre, used in this wide range of compression fittings contains a highly effective corrosion inhibitor. It's an outstanding material, ideally suited to the high quality standards maintained by IBP, and can be used where dezincification could cause problems.

DZR fittings are marked with the **CR** symbol, recognised and accepted by the Water Industry and the British Plumbing Fittings Manufacturers' Association, and now specified in British Standards as a mark denoting material of assessed capability of resistance.

Within this extensive DZR range, a few fittings are retained in gunmetal for technical and commercial reasons.

Where dezincification resistant brass is used, it complies with the requirements of EN12164 CW602N and EN12165 CW602N. Table A provides a list of materials and the relevant European Norme that governs its performance.

Health and Safety

It is the responsibility of the end user to ensure that adequate protection is available where required and the necessary information regarding possible health and safety regulations is adhered to. Copper and copper alloy fittings are considered non-hazardous under normal circumstances.

All per COSHH 4 REG 1988.

Table A

Material	Specification	
Brass (Forging)	EN12165	CW617N
Brass (Turning)	EN12164	CW617N
DZR Brass (Forging)	EN12165	CW602N
DZR Brass (Turning)	EN12164	CW602N
DZR Brass (Ring Tube)	EN12164	CW602N
Gunmetal (Red Brass)	DIN50930-6	

Stress Corrosion

Within certain environments, particularly those containing a corrosive medium, stress corrosion of duplex brass fittings may occur. For further information, please contact our Technical Department.

One Fitting for Many Tubes

Effecting a joint is simple, requiring nothing more than suitable spanners whether it be a 6mm or a 108mm fitting. The symmetrical compression ring seals within the cone angle of the fitting and provides a two-point seal on the tube when the capnut is tightened the correct number of turns (Table D, page 15). The joint so made will withstand pressures far in excess of those normally experienced.

To facilitate installations we also offer a range of accessories that reduce torque loading when making a joint in sizes 35mm to 76.1mm. Whilst most need only a simple compression ring change, the 42mm and 54mm require a flanged adaptor set.

Conex compression fittings are especially advantageous in retrofit plumbing schemes, in installations where space is confined, or when the use of heat must be avoided.

Copper

Conex compression fittings are capable of joining size-compatible copper tubes that are manufactured in accordance with EN 1057 (formerly BS 2871: Part 1) and many other standards including ISO 274.

Stainless Steel

Conex compression fittings are capable of joining size-compatible stainless steel tubes such as those manufactured in accordance with BS 4127 and DIN 17455 and 17457.

When the installer is using tube diameters 35mm to 76.1mm, it is recommended that our low torque fittings are used.

Medium Density Polyethylene – MDPE

Whether you are joining underground (BS 6572) or above ground (BS 6730), our ISO Conex fittings, valves, liners and adaptors provide a comprehensive range enabling a fast and secure joint to be made on pipe diameters up to 32mm.

Other Types of Plastic Pipe

IBP offer a variety of fittings for joining tubes such as cross-linked polyethylene (PE-X) and polybutylene (PB), from simple tube liners to precision made adaptor sets and manifolds, covering 12mm to 32mm tube outside diameters with wall thicknesses ranging from 1.3mm to 4.4mm. There are also adaptor sets that permit the use of standard compression fittings. Please contact us for more details about this range of fittings.

Quality Assurance

The Company is a B.S.I. Registered Firm of assessed capability, Registration Number FM 11836, manufacturing in accordance with EN ISO 9001:2000.

Conex fittings are manufactured in accordance with EN 1254-2 and 4 (formerly BS 864: Part 2 and 4).

Most fittings in the range are covered by the B.S.I. Kitemark under Licence No. KM 07283 (detailed list available upon request). Listing can also be found in the WRAS Water Fittings and Materials Directory under 'Kitemarked and Quality Assured Fittings'.

Conex fittings are also approved by many other European test institutions such as KIWA, SITAC, GASTEC, DET NORSKE VERITAS and DVGW.

In addition to audits carried out by the British Standards Inspectorate, an internal audit system is also in operation to further enhance quality control.

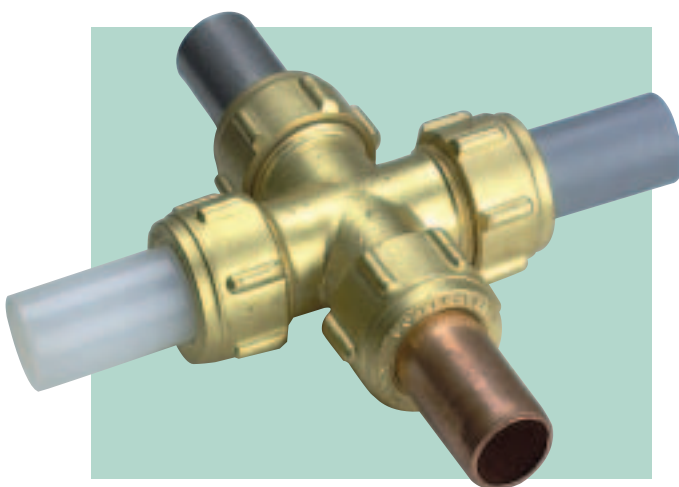

(EN1254)



Certificate No. FM 11836

Design

Conex fittings are designed to comply with relevant standards and to minimise flow restriction.

The symmetrical compression ring provides a seal within the cone of the fitting and a two point seal on the tube.

The simple principle of the Conex compression joint is shown in the following diagram. The compression ring is compressed between two differing tapers within capnut and fitting respectively. The sharper angle of the body taper constitutes a larger area of ring contact in the fitting body, thus reducing any tendency for the tube to revolve as the joint is being secured.

Tightening the capnut to secure the joint causes the compression ring to change form, making a perfect metal x metal seal that actually indents the tube on both points of contact. This ensures a joint that is easily capable of withstanding pressures far in excess of those experienced in normal usage. In tests on 15mm EN1057-R250 (half hard) the tube bursts without affecting the joint.

Fine threads have been avoided to prevent the danger of cross threading. Threads on the 8mm, 12mm and 15mm compression ends are equal to 1/4", 3/8" and 1/2" BSP in accordance with BS 2779/ISO 228. Other thread sizes are to BS 84 or ISO 7.

Conex unique ribbed pattern capnuts are supplied on 6mm to 28mm fittings. Sizes 35mm, 42mm and 54mm are supplied with octagonal capnuts. Fittings in 66.7mm, 76.1mm and 108mm sizes incorporate loose compression plates, where tightening is through six 3/8" BSW nuts and allthreads.

For high torque applications, devices are available to facilitate installation.

Finish Availability

Apart from the natural finish, fittings are also offered nickel plated or chrome plated in accordance with EN 248.

Note: When fittings are to be plated by the customer, it is recommended that our Technical Department is contacted for guidance.

Connecting Threads

Taper male threads are in accordance with ISO 7 and EN 1254-4. Parallel male threads are in accordance with EN 1254-4 and ISO 228.

Parallel female threads are in accordance with EN 1254-4 (BS 864: Part 2 Clause 4(c)) and ISO 228.

Generally, fittings are manufactured with parallel threads but certain products are offered with taper threads. Reference to our product range will provide more details.

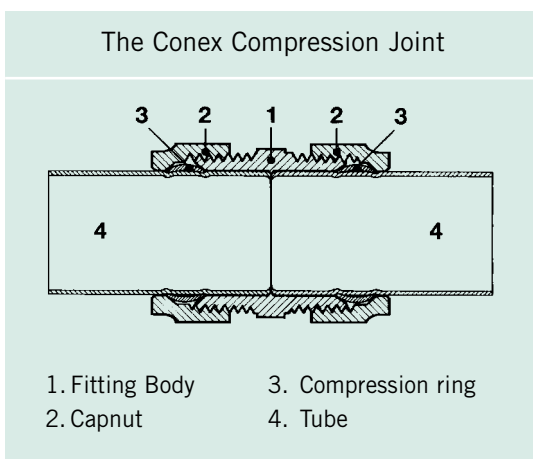

Performance

Hydraulic working temperatures and pressures shown are based on EN 1254-2. Table B, prepared from the stated values, enables direct reading of intermediate values.

Fittings up to and including 28mm can be used at higher pressures than those shown provided that the installation does not impart additional tensile loads on the joints. Please contact our Technical Department for further data. They may also be used with light mineral oils, L.P.G., natural gas or compressed air, in accordance with Table C, when assembled with copper tubes to EN 1057 (formerly BS 2871: Part 1 table X, Z, Y).

Table B

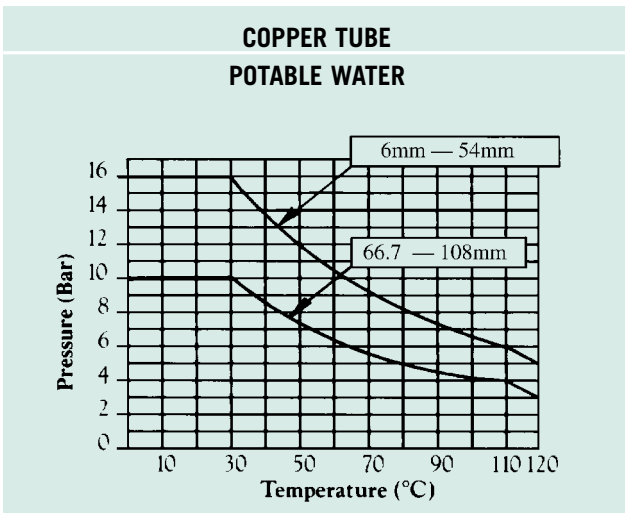

Water Flow Resistance Through Fittings

Data is readily available in Publication 33 issued by the Copper Development Association.

Internal Reducers

Sizes not quoted within our range may be achieved via the use of internal reducers either as a three piece or one piece configuration. They are manufactured from DZR (dezincification resistant material **CR**) or gunmetal, thereby being resistant or immune to dezincification.

N.B. one piece reducers are not designed for use with plastic pipes.

The minimum number of turns required is based on the reduced diameter. Thus for a 22mm x 15mm reducer, refer to Table D for the number of turns required for 15mm.

Reducers rely on a metal x metal seal and care should be taken to avoid damage prior to assembly. Should difficulty be experienced, the use of a WRAS listed sealant is permitted.

Table C

COPPER TUBE			
For Use With	Tube Sizes	Temps Not Exceeding	Max Working Pressures
	Ø mm	°C	Bar
Potable Water or Light Mineral Oils	6 to 54	30	16
		65	10
		95	7
		110	6
LPG, Natural Gas	8 to 28	30	10
		65	6
		110	4
Compressed Air	8 to 28	30	1
		30	7

Making a Joint

6mm–54mm

1. Ensure that the tube and fitting sizes are compatible. Cut the tube end square but ensure tube retains its shape. The tube will then make even contact with the tube stop in the body of the fitting. The use of an appropriate tube cutter is recommended where practicable.
2. Remove any burrs from the tube, both inside and out.



3. Where necessary, insert a suitable tube liner.
4. One of two methods can be employed for making the joint.
 - a) The tube can be firmly inserted into the Conex compression fitting without removing the capnut and compression ring.

Care should be taken to ensure that the compression ring is in the correct position and that the tube makes firm contact with the tube stop in the body of the fitting.
 - b) The capnut and compression ring can be removed, located onto the tube in logical sequence, and the tube fully inserted into the Conex compression fitting.



5. In both cases, tightening of the capnut is effected by hand as far as possible, followed by the recommended minimum number of turns (refer to Table D) with a suitable spanner. Tools with serrated jaws should not be used. A few drops of light oil applied to the screw thread before tightening the nut will reduce the load required to reach the number of turns. This is particularly applicable to the larger sizes.



N.B. When joining soft copper tube to EN 1057-R220 or plastic pipes, it is essential that an appropriate tube liner is also fitted.

The Conex compression joint makes a metal x metal seal which normally eliminates the need for jointing compounds and sealants. On larger sizes, particularly 54mm, it may be necessary to use an additional WRAS approved sealant. Jointing instructions, when using sealant, are available from our Technical Department.

High Torque Installations

IBP has designed devices to reduce tightening torque for 35mm to 76.1mm applications. They are particularly useful where space is restricted and/or stainless steel tube is being joined. When using stainless steel tube, water quality approved PTFE coated compression rings must be used on sizes 35mm and above. Whilst most sizes are a simple compression ring change, we recommend that 42mm and 54mm sizes use a flanged adaptor set comprising one flange, one compression plate, four allthreads, four nuts and one PTFE coated compression ring. Assembly is commenced by discarding the standard capnut and compression ring and securing the threaded flange to the exposed end of the fitting and is completed by following the instructions for flanged fittings 66.7mm –108mm.

Note: The installation procedures within this brochure are generally for water applications. Installation procedures may vary for non-water applications and other tube material specifications. In these cases you are advised to contact our Technical Department for clarification.

Assembly of Coned Joints and Screwed Fittings

Coned Joints

Cone face connectors to EN 1254-4 (BS 864: Part 2) rely on a metal x metal seal and care should be taken to avoid damage prior to assembly. Should difficulty be experienced, the use of a WRAS listed sealant is permitted. Do not overtighten.

Threaded Joints for Liquid Applications

The use of a WRAS listed sealant or tape (e.g. PTFE) is recommended for making joints on fittings with taper male threads. For making joints with parallel connector threads, a good quality washer made from a WRAS listed material should be used. Suitable washers are supplied with Conex tap connector fittings and these should be used.

Threaded Joints for Gas Applications

An approved gas sealant must be used for making joints on fittings with taper male threads and female parallel threads.

Table D

MATERIAL	TUBE SPECIFICATION	SIZE ►	6mm to 18mm	22mm	28mm to 54mm		
HALF HARD AND HARD COPPER	EN1057-R250 (Half Hard)	Nº of turns	1¼	1	¾		
		Liner	none	none	none		
	EN1057-R290 (Hard)	Nº of turns	1	¾	½		
		Liner	none	none	none		
SOFT COPPER	EN1057-R220	SIZE ►	8mm	10mm	15mm	18mm	22mm
		Nº of turns	1¼	1¼	1¼	1¼	1
		Liner: SC1	8 x 1.0	10 x 1.0	15 x 1.0	18 x 1.0	22 x 1.0
STAINLESS STEEL	BS4127	SIZE ►	6mm to 22mm	28mm	35mm to 54mm	67mm to 76.1mm	
		Nº of turns	¾	½	½*	*	
		Liner	none	none	none	none	
FLEXIBLE	POLYBUTYLENE (PB)	SIZE ►	10mm	15mm	22mm	28mm	
		Nº of turns	1½	1½	1½	1½	
		Liner: PP	10 x 1.5/1.8	15 x 1.7/2.0	22 x 2.0/2.3	28 x 2.6/2.9	
	CROSS LINKED POLYETHYLENE (PE-X)	SIZE ►	10mm	15mm	22mm	28mm	
		Nº of turns	1½	1½	1½	1½	
		Liner: PP	10 x 1.5/1.8	15 x 1.5/1.8	22 x 2.0/2.3	28 x 2.6/2.9	
	MEDIUM DENSITY POLYETHYLENE (MDPE)	SIZE ►	20mm	25mm	32mm		
Nº of turns		1½	1½	1½			
	Liner: PY	20 x 2.3/2.6	25 x 2.3/2.6	32 x 3.0/3.4			

PLEASE CONSULT OUR TECHNICAL DEPARTMENT WHEN USING OTHER MATERIALS.

* When using tube diameters 35mm to 76.1mm, it is recommended that our low torque fittings are used. Please refer to our Technical Department.

Flanged Fittings

66.7mm - 108mm

1. Ensure that the tube and fitting sizes are compatible. Cut the tube end square but ensure tube retains its shape. The tube will then make even contact with the tube stop in the body of the fitting.
2. Remove any burrs from the tube, both inside and out.
3. One of two methods can be employed for making the joint.
 - a) The tube can be firmly inserted into the Conex compression fitting without removing the compression plate and compression ring. Care should be taken to ensure that the compression ring is in the correct position and that the tube makes firm contact with the tube stop in the body of the fitting. The $\frac{3}{8}$ " BSW nuts are then tightened until hand tight and the same amount of allthread shows through each nut.

- b) The compression plate and compression ring can be removed by first unscrewing the $\frac{3}{8}$ " BSW nuts. Then by locating the compression plate and compression ring onto the tube in logical sequence, the tube is inserted into the fitting, or fitting onto the tube, until positive contact is reached. The compression ring and compression plate are then correctly situated in their original position, the nuts are replaced and tightened until hand tight and the same amount of allthread shows through each nut.
4. In both cases the nuts are then further tightened a minimum of 2 full turns in increments of $\frac{1}{2}$ a turn only, on each position in the sequence shown in the diagram. To avoid overtightening the maximum number of turns is $2\frac{1}{2}$.

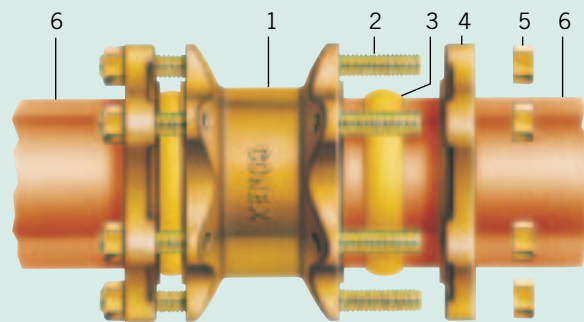

- | | |
|---------------------|----------------------|
| 1. Fitting | 4. Compression Plate |
| 2. Allthread | 5. Nut |
| 3. Compression Ring | 6. Tube |

Note: The compression plate before and after correct assembly should be parallel to the face of the fitting body.

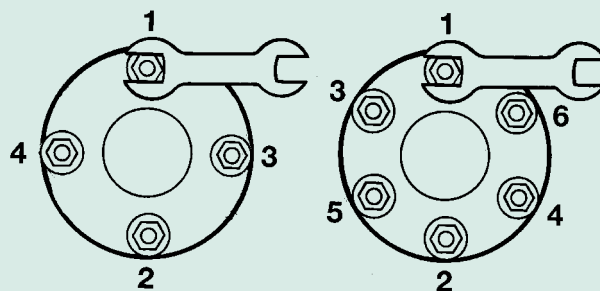

Installation Dimensions (capnuts hand tight)

COMPRESSION END TUBE STOP DIMENSION Standard for all Components

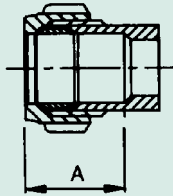

Size	A (mm)
15	21.8
22	25.4
28	26.0
35	30.0

302 or S302 STRAIGHT COUPLER Conex x Male Thread (Parallel)

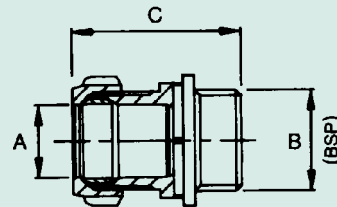

Size	A (mm)	B (BSP)	C (mm)
15 x 1/2	15	1/2	37.5
22 x 3/4	22	3/4	42.5
22 x 1	22	1	41.5
28 x 1	28	1	45.0

63 CAPNUT

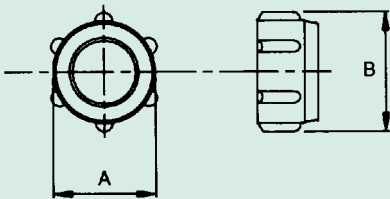

Size	A (mm)		B (mm)
	Maximum	Minimum	
15	24.55	24.33	27.3
22	32.74	32.53	36.5
28	39.16	38.94	45.2
35	46.85	46.35	50.0

303 or S303 STRAIGHT COUPLER Conex x Female Thread (Parallel)

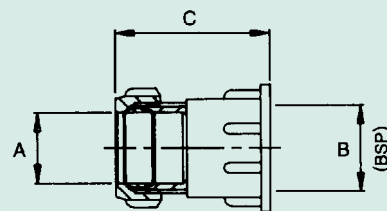

Size	A (mm)	B (BSP)	C (mm)
15 x 1/2	15	1/2	39.5
22 x 3/4	22	3/4	43.5
22 x 1	22	1	49.0
28 x 1	28	1	48.0

301 or S301 STRAIGHT COUPLER Conex x Conex

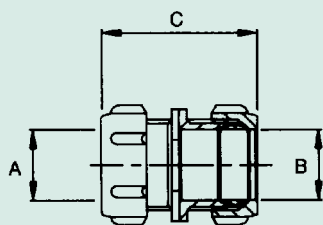

Size	A (mm)	B (mm)	C (mm)
15 x 15	15	15	44.3
22 x 15	22	15	50.5
22 x 22	22	22	52.0
28 x 28	28	28	53.5

303SF or S303SF STRAIGHT COUPLER Conex x Swivel Female Thread

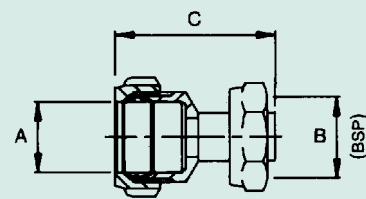

Size	A (mm)	B (BSP)	C (mm)
15 x 1/2	15	1/2	44.0
15 x 3/4	15	3/4	44.5
22 x 3/4	22	3/4	48.0
28 x 1	28	1	49.0

N.B. Conex capnuts greater than 28mm will have octagonal external form.
For other dimensional data, please contact our Technical Department.

321 or S321 TANK CONNECTOR
Conex

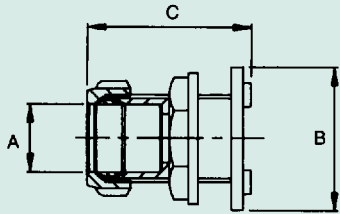

Size	A (mm)	B (mm)	C (mm)
15	15	35.0	49.0
22	22	43.0	46.0
28	28	49.0	48.0
35	35	56.5	45.5

402 or S402 ELBOW
Conex x Male Thread (Parallel)

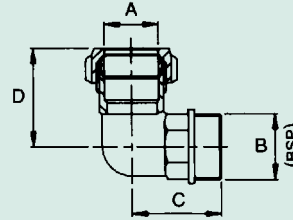

Size	A (mm)	B (BSP)	C (mm)	D (mm)
15 x 1/2	15	1/2	25.7	34.0
22 x 3/4	22	3/4	32.0	37.5
22 x 1	22	1	34.5	42.7
28 x 1	28	1	38.5	43.2

323 or S323 STOP END
Conex

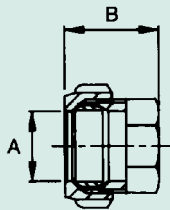

Size	A (mm)	B (mm)
15	15	26.0
22	22	27.0
28	28	31.0
35	35	34.7

403 or S403 ELBOW
Conex x Female Thread (Parallel)

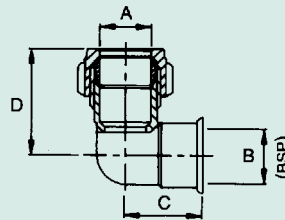

Size	A (mm)	B (BSP)	C (mm)	D (mm)
15 x 1/2	15	1/2	15.3	34.3
22 x 3/4	22	3/4	28.5	39.4
22 x 1	22	1	30.5	42.6
28 x 1	28	1	35.1	43.9

401 or S401 ELBOW
Conex x Conex

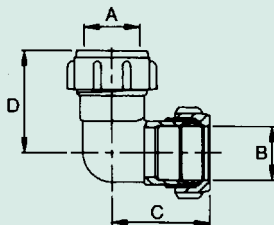

Size	A (mm)	B (mm)	C (mm)	D (mm)
15 x 15	15	15	31.5	31.5
22 x 22	22	22	36.9	36.9
28 x 28	28	28	41.9	41.9
35 x 35	35	35	48.2	48.2

403SF or S403SF ELBOW
Conex x Swivel Female Thread

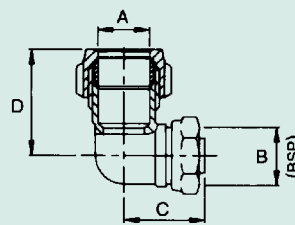

Size	A (mm)	B (BSP)	C (mm)	D (mm)
15 x 1/2	15	1/2	27.4	31.4
15 x 3/4	15	3/4	33.5	29.5
22 x 3/4	22	3/4	32.0	36.5
28 x 1	28	1	44.0	41.0

N.B. Conex capnuts greater than 28mm will have octagonal external form.
For other dimensional data, please contact our Technical Department.

**403WL or S403WL WALL
PLATE ELBOW**
Conex x Female Thread (Parallel)

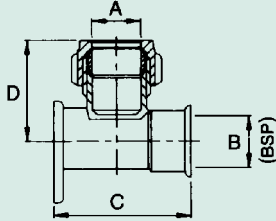

Size	A (mm)	B (BSP)	C (mm)	D (mm)
15 x 1/2	15	1/2	41.8	33.8
22 x 1/2	22	1/2	47.0	36.9
22 x 3/4	22	3/4	54.0	38.0
28 x 1	28	1	65.0	44.0

615 or S615 TEE
Conex x Conex x Male Thread (Parallel)

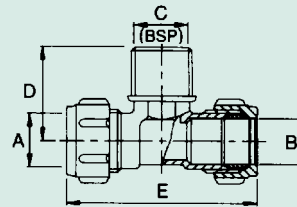

Size	A (mm)	B (mm)	C (BSP)	D (mm)	E (mm)
15 x 15 x 1/2	15	15	1/2	25.7	68.0
15 x 15 x 3/4	15	15	3/4	34.0	75.5
22 x 22 x 3/4	22	22	3/4	32.6	77.0
28 x 28 x 1	28	28	1	39.7	89.6

601EQ or S601EQ TEE-EQUAL
Conex All Ends

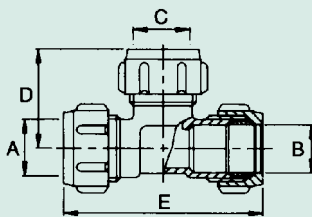

Size	A (mm)	B (mm)	C (mm)	D (mm)	E (mm)
15 x 15 x 15	15	15	15	31.5	63.0
22 x 22 x 22	22	22	22	36.9	73.8
28 x 28 x 28	28	28	28	41.9	83.8
35 x 35 x 35	35	35	35	48.2	96.4

617 or S617 TEE
Conex x Conex x Female Thread (Parallel)

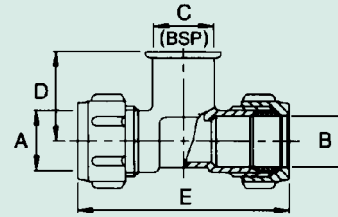

Size	A (mm)	B (mm)	C (BSP)	D (mm)	E (mm)
15 x 15 x 1/2	15	15	1/2	25.4	66.2
15 x 15 x 3/4	15	15	3/4	26.2	74.1
22 x 22 x 3/4	22	22	3/4	28.5	78.2
28 x 28 x 1	28	28	1	35.0	85.8

601 or S601 TEE-UNEQUAL
Conex All Ends

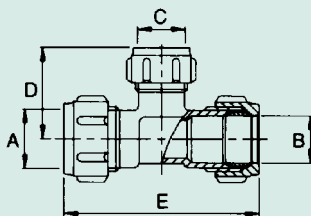

Size	A (mm)	B (mm)	C (mm)	D (mm)	E (mm)
22 x 15 x 15	22	15	15	34.3	65.9
22 x 15 x 22	22	15	22	36.9	70.2
22 x 22 x 15	22	22	15	34.3	69.7
28 x 28 x 15	28	28	15	37.9	68.2

684 or S684 TEE
Conex x Female Thread (Parallel) x Conex

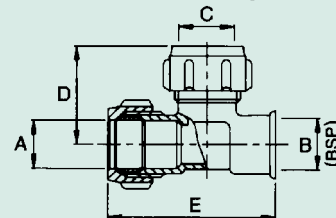

Size	A (mm)	B (BSP)	C (mm)	D (mm)	E (mm)
15 x 1/2 x 15	15	1/2	15	33.0	55.0
22 x 1/2 x 22	22	1/2	22	37.0	63.0
22 x 3/4 x 22	22	3/4	22	39.5	65.7
28 x 1 x 28	28	1	28	45.0	79.0

N.B. Conex capnuts greater than 28mm will have octagonal external form.
For other dimensional data, please contact our Technical Department.

Conex | Bänninger

Please see our website for the full Conex range at www.ibpconex.co.uk
or contact the sales team on: 0121 557 2831 or email: salesuk@ibpgroup.com
For technical information please email our technical department at: technical@ibpgroup.com



Conex Universal Limited: Whitehall Road, Tipton, West Midlands, DY4 7JU, UNITED KINGDOM. Tel: +44 (0)121 557 2831 Fax: +44 (0)121 520 8778
email: export@ibpgroup.com, salesuk@ibpgroup.co.uk, technical@ibpgroup.com, literature@ibpgroup.com, web: www.ibpgroup.com, www.ibpconex.co.uk

an IBP GROUP company.